MODERN DIGITAL BACKEND SYSTEMS FOR THE RADIO TELESCOPES OF THE QUASAR VLBI NETWORK

D.A. Marshalov 
*Institute of Applied Astronomy RAS,
Saint Petersburg, Russia, marshalov@iaaras.ru*

S.A. Grenkov 
*Institute of Applied Astronomy RAS,
Saint Petersburg, Russia, grenkov@iaaras.ru*

A.S. Berdnikov
*Institute of Applied Astronomy RAS,
Saint Petersburg, Russia, as.berdnikov@iaaras.ru*

L.V. Fedotov 
*Institute of Applied Astronomy RAS,
Saint Petersburg, Russia, fedotov@iaaras.ru*

Abstract. This paper presents modern digital signal conversion systems used for radio telescopes of the Quasar VLBI network. We briefly trace the evolution of signal conversion equipment from analog and hybrid solutions to a multifunctional digital backend system (MDBE) providing fully digital processing of received signals over a wide frequency range. The architecture, main technical characteristics, and operating modes of MDBE are described, along with specific features of its application on the RT-13 and RT-32 radio telescopes. It is shown that the use of MDBE enables unification of signal conversion hardware, supports both broadband and narrowband very long baseline interferometry modes, and allows spectral and radiometric observations to be implemented within a single hardware–software

platform. We give examples of practical applications demonstrating the system’s efficiency, stability of signal path parameters, and compatibility with national and international data recording and transmission standards. Prospects for further development of the system and expansion of the range of scientific and applied problems are also discussed.

Keywords: radio telescope, radio astronomical equipment, signal conversion system, digital signal processing.

INTRODUCTION

Modern radio astronomy, including very long baseline interferometry (VLBI), relies largely on digital signal conversion and processing systems. It is these systems that determine the available observation band, the sensitivity of radio telescopes, and the possibility of implementing various recording modes — from broadband VLBI observations to spectral and radiometric studies. Development of signal conversion equipment is one of the key trends in state-of-the-art radio astronomy technique and is directly related to the transition from analog and hybrid solutions to fully digital processing methods.

The Quasar VLBI network is an important element of the Russian radio astronomy infrastructure and is integrated into the global VLBI network [Ipatov, 2013]. It is used for solving space geodesy and timing problems, as well as for conducting astrophysical, radiometric, and spectral studies. Radio telescopes of this complex operate both as part of the network and independently, which demands higher standards of universality and functionality of signal conversion systems that provide preprocessing of received data.

The radio telescope signal digital backend system is a multichannel hardware–software complex controlled by a computer and connected to outputs of intermediate frequencies (IF) of receiving equipment. This system performs signals extraction in given spec-

tral IF regions, their frequency conversion with separation of upper and lower side bands, filtering, and subsequent analog-to-digital conversion. A digital data stream is generated based on quantized signals, which can be recorded in the required format and transmitted to a processing center along with time stamps and synchronization signals. Thus, the signal conversion system plays a key role in the operation of radio telescopes, determining the quality and information content of obtained observational data.

In the early stages of the development of the Quasar VLBI network, fully analog circuits were used in signal conversion systems. Later, the Institute of Applied Astronomy of the Russian Academy of Sciences (IAA RAS) developed the hybrid system P1002M in which conversion to video frequencies was carried out on analog chips; analog-to-digital conversion, on video frequencies; and digital filtering, on field-programmable gate arrays (FPGAs). Transition to hybrid solutions made it possible to reduce dimensions of equipment and improve the quality of data obtained from VLBI observations. The next stage of development was the creation of a broadband digital backend system (BRAS) with a 512 MHz bandwidth, which compensated for sensitivity losses and initiated VLBI observations in radio telescopes RT-13 with small-diameter fully steerable antennas. This marked the transition to the third generation of systems in which analog processing was still applied,

primarily in radio receiving paths. For a long time, further development of such systems was hindered by limitations on the speed of analog-to-digital converters and FPGAs. With all its advantages — compactness, compatibility with eVLBI modes [Min-Gyu Song et al., 2005; Salnikov et al., 2023], and the ability to generate output data streams up to 16 Gbit/s — BRAS had significant limitations. It was designed for RT-13 and could not be employed with other receiving systems of the Quasar VLBI network. The operating band proved insufficient for modern requirements, which call for bands of at least 1 GHz. Furthermore, the system primarily supported the broadband VLBI mode, whereas a significant part of international programs continues to apply narrow-band recording. A significant disadvantage was also the lack of control of internal signal delays, which is necessary to improve the accuracy of geodetic and astrometric measurements.

The combination of these factors necessitated the development of a multifunctional digital signal conversion system capable of providing fully digital signal processing in a wide frequency band, unifying operating modes of radio telescopes, and improving the accuracy of synchronization. At IAA RAS, this system was implemented as a multifunctional digital backend (MDBE) system, designed for applying to the radio telescopes RT-13 and RT-32 of the Quasar VLBI network and focused on solving a wide range of scientific and applied problems.

1. MULTIFUNCTIONAL DIGITAL BACKEND SYSTEM

The development of the MDBE system was aimed at creating a universal hardware and software solution capable of replacing several specialized systems previously adopted on radio telescopes of the Quasar VLBI network. Unlike earlier developments focused on radio telescopes of individual types or specific observation modes, the MDBE system was originally designed as a single platform for implementing broadband and narrowband VLBI modes, as well as spectral and radio-metric observations. Its key feature is the complete transition to digital signal processing in a wide frequency band when analog path sections are minimized. The system provides digitization of signals directly near the receiving equipment of a radio telescope, which significantly reduces losses and distortions associated with the transmission of analog signals through long feed lines, as well as improves the stability of signal path parameters. This approach is especially important for radio

telescopes with different configurations of receiving systems and a wide range of observation modes.

In terms of its technical parameters, the MDBE system compares well with up-to-date foreign digital signal conversion systems employed in radio astronomy and VLBI observations, and in some characteristics it outperforms solutions previously used in the Quasar VLBI network. Table compares the main MDBE parameters and a number of foreign analogues, including the DBBC3 (EU), R2DBE (USA), K6/GALAS (Japan), and KVN DAS (South Korea) systems [Tuccari et al., 2018; Vertatschitsch et al., 2015; Sekido et al., 2015, Oh et al., 2011]. The comparison shows that the MDBE system combines a high total processing bandwidth, a large number of independent channels, and a flexible configuration of output data streams, which ensures its versatility in solving a wide range of scientific and applied problems.

The MDBE system is modular and includes up to 12 digital signal processing (DSP) units, a synchronization and control unit (SCU), a power module, and a cross-board (Figure 1). There is a separate cooling module that ensures stable thermal conditions. This architecture allows us to flexibly configure the system depending on the number of receiving channels and features of receiving equipment of the radio telescope, maintaining a single hardware and software platform. The MDBE system is installed in close proximity to the radio telescope's receiving equipment, which significantly reduces signal losses and distortions in analog paths and ensures digitization of signals at each intermediate frequency output. Each DSP unit contains a 10-bit analog-to-digital converter (ADC) operating at a sampling frequency of 4096 MHz and capable of processing signals in a bandwidth up to 2 GHz, as well as FPGA for digital processing. Output data streams are transmitted via optical channels by SFP+ and QSFP transceivers to the radio telescope's data buffering and transmission system [Salnikov et al., 2023]. To prevent ADC saturation, each input path has a software-controlled attenuator with an attenuation range 0–31.75 dB and a step of 0.25 dB, as well as an embedded direct current (DC) blocking circuit that suppresses the constant component and frequencies below 1 MHz, along with a low-pass filter (LPF), which eliminates aliasing. This approach ensures stable operation of the system at various input signal levels and simplifies its adaptation to different receiving systems of the network's radio telescopes.

Main parameters of the MDBE system and its foreign analogues

Parameter	MDBE (Russia)	DBBC3 (EU)	R2DBE (USA)	K6/GALAS (Japan)	KVN DAS (South Korea)
Number of channels	12	4	2	4	4
Max. bandwidth (MHz)	2048	4096	2048	1024	1024
Max. total data rate (Gb/s)	96	128	16	40	8
Output signal quantization	1/2/8/16	2/10	2	1/2	2
Output data format	VDIF, 10GbE (40GbE)	VDIF, 10GbE/40GbE	VDIF, 10GbE	VDIF; VTP/UDP/IP, 10GbE	VSI-H→VDIF, 10GbE
Location	antenna	lab. building	lab. building	lab. building	lab. building

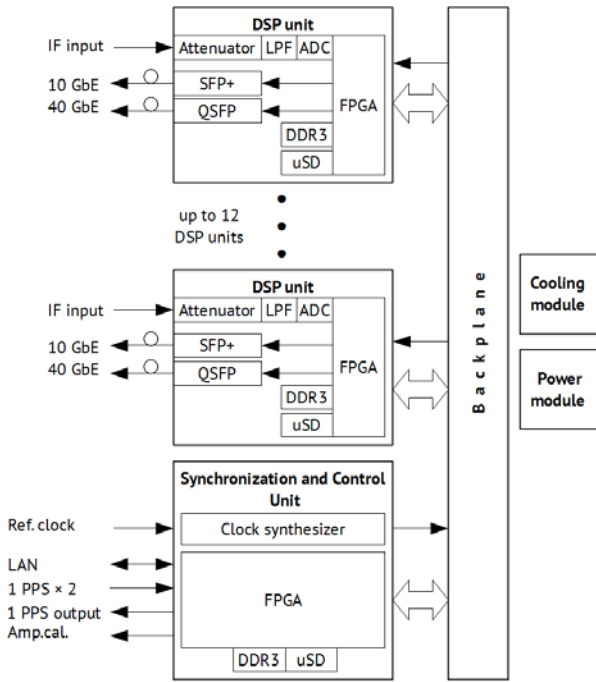

Figure 1. MDBE system structure: DSP — digital signal processing unit; Att. — attenuator; LPF — low-pass and high-pass filters (differential converter with DC blocking circuit embedded in the DSP unit at the ADC input); ADC — analog-to-digital converter; FPGA — field-programmable gate array; SFP+ and QSF — optical transceivers; DDR — memory chip; μ SD — micro SD memory map; LAN — local area network

The synchronization and control unit, based on the same component base as DSP, provides centralized control of the system and distribution of synchronization signals. The MDBE system is controlled from the main computer of the radio telescope via the Ethernet network, and SCU interacts with DSP units through high-speed LVDS channels with a bit rate of 256 Mb/s. The embedded clock synthesizer receives an external reference signal with a frequency of 5, 10, or 100 MHz and generates synchronization signals distributed across all DSP units. SCU also generates one pulse per second 1PPS time-stamp signal, which can be synchronized with the radio telescope's time scale. Discrepancies with respect to global navigation satellite system (GNSS) pulses are monitored with an accuracy of 4 ns, enabling the timely detection and elimination of synchronization errors critical for high-precision VLBI observations.

The MDBE system is installed in the radio telescope focal cabin, which makes it possible to abandon transmission of analog signals through extended and movable antenna cable lines. This arrangement significantly reduces the effect of instabilities associated with temperature changes, mechanical deformations, and cable movement. The system was developed in standard 3U Europac PRO chassis designed for operation under hard conditions and suitable for the moving part of radio telescopes. The modular architecture of the MDBE system allows us to implement various configurations of the system without changing its dimensions and general layout. Radio telescopes RT-13 use the 8-channel MDBE version,

whereas for radio telescopes RT-32 the 4-channel modification of the system has been developed which operates in an intermediate frequency range 100–1000 MHz and can select signals from ten receivers of five bands (L, S, C, X, and K) in two orthogonal polarizations. Despite the differences in configuration, the overall dimensions and design of the system for RT-13 and RT-32 remain the same (Figure 2), which simplifies its operation and maintenance.

The stable thermal environment of the MDBE system is provided by a separate 1U-high cooling unit equipped with three controlled fans. The fan speed is controlled automatically based on readings of embedded temperature sensors located in the crossboard, as well as in DSP units and SCU. This approach allows us to maintain optimal temperature conditions of the system under changing external environment. To improve the reliability of the MDBE system, continuous monitoring of voltages and currents of all critical power supply circuits has been implemented. The parameters are monitored by embedded hardware and software tools, and, when measured values exceed allowable limits, a radio telescope operator receives a warning about a possible malfunction. This ensures timely detection of system malfunctions and reduces the risk of failures during observations.

The functionality of the MDBE system is largely determined by FPGA firmware of DSP units, which are loaded into the system depending on the selected operating mode. The firmware fulfils all critical tasks of digital signal processing and synchronization, whereas the functions of control and transmission to the supervisory computer are performed by the embedded ARM Cortex-A9 processor. The logic of digital processing and synchronization is implemented in the SystemVerilog language; and the software of the embedded processor, in the C language. The FPGA firmware of SCU is mainly responsible for the configuration and coordination of the system, distribution of synchronization signals, and interaction with the central computer of the radio telescope. The FPGA firmware of DSP units, in turn, defines the output data format and specific algorithms for processing received signals, which ensures the flexibility of the system and the ability to quickly adapt to various observational tasks. The generalized logical structure of the FPGA firmware of a DSP unit is presented in Figure 3 and includes three main operational units.



Figure 2. Four-channel MDBE system for radio telescopes RT-32

The main digital processing block performs synchronization of input data streams, demultiplexing of four digital streams from ADC, and parallel processing of 16 signal samples. This block carries out the basic digital processing operations necessary to generate output data streams in a given format.

The ADC control block provides its calibration, overflow check, and input signal parameter analysis. In particular, this block fulfils the system's phase calibration functions used to evaluate and compensate for internal signal path delays.

The synchronization and system control block is responsible for communicating with the radio telescope main computer, direct memory access (DMA), formation of system clocks, and operation of the embedded processor. This unit ensures coordinated functioning of all firmware components and supports control and diagnostic information sharing.

The MDBE system performs the operation of the radio telescopes of the Quasar VLBI network in several basic modes [Marshalov et al., 2024] covering both VLBI tasks and single dish radiometric and spectral observations.

The broadband VLBI mode — the system provides recording of signals in the 2048, 1024, 512, 128, and 64 MHz bandwidths. A bandwidth is selected programmatically and allows us to adapt recording parameters to the requirements of specific observation programs and data transmission channel capacity.

The narrowband VLBI mode — the MDBE system generates up to 16 independently tunable frequency channels for each input of the system. A bandwidth of 32, 16, 8, 4, 2, or 0.5 MHz can be set for each channel, which ensures compatibility with international VLBI observation programs using narrowband recording, as well as flexible adjustment of spectral band splitting.

The spectrometer mode is designed to record power spectra of received signals with a given frequency resolution and is used during spectral radio astronomy observations. Implementation of this mode in digital form al-

lows us to obtain stable and replicable spectra in a wide frequency bandwidth.

Radiometer mode measures the integrated power of received signals. This mode is used for radiometric observations and calibration of radio telescope receiving systems.

Anti-interference spectral-selective radiometer mode is a separately implemented mode in which given spectral regions are selected with subsequent radiometer processing. This mode increases the resistance of observations to radio frequency interference and expands the possibilities of using the MDBE system for a challenging electromagnetic environment.

To ensure reliable operation of the MDBE system and control of signal processing accuracy, diagnostic hardware and software tools have been developed which are integrated into the radio telescope control system of the Quasar VLBI network. These tools provide remote monitoring of the radio telescope signal path from outputs of receivers to inputs of MDBE units. As part of diagnostic procedures, signal power is measured across all channels, as well as power and phase spectra are obtained and analyzed. This allows timely detection of malfunctions in receiving paths, violations of signal level matching, and possible failures in individual system elements. Additionally, tools have been implemented to evaluate phase-frequency responses and group delays, as well as to analyze signal harmonic phases during phase calibration in each channel [Nosov, 2019]. Such measurements are used to control internal signal path delays and to improve the accuracy of VLBI observations, in particular in geodesy and astrometry modes. Integration of diagnostic functions directly into the digital signal conversion system enables us to perform real-time monitoring of parameters without external measuring equipment, which greatly simplifies the operation of radio telescopes and increases the reliability of observations.

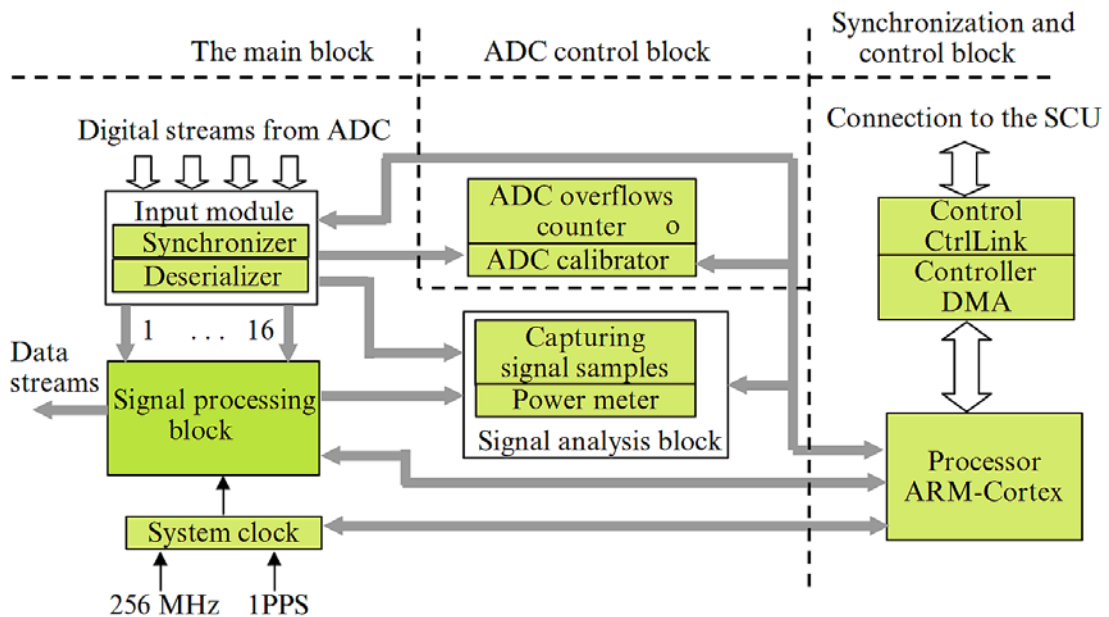

Figure 3. Generalized logical structure of the FPGA firmware of DSP

2. APPLICATION OF DIGITAL SIGNAL CONVERSION SYSTEMS TO RADIO TELESCOPES OF THE QUASAR VLBI NETWORK

In 2011–2023, VLBI observations by RT-32 of the Quasar VLBI network were performed using the hybrid signal conversion system R1002M, whereas the radio telescopes RT-13 were initially equipped with BRAS. For radiometer studies on RT-32, analog modules PRM-2 developed at IAA RAS in the 1990s were used, and spectrometric problems were solved with the aid of experimental digital modules P3901 and P3902. Thus, observations of various types were provided by disparate hardware differing in architecture and principles of signal processing.

Since 2020, the phased transition of all radio telescopes of the Quasar VLBI network to a multifunctional digital backend system has begun. On RT-32, the MDBE system was initially operated in parallel with R1002M, which allowed comparative tests to be done under real observation conditions. The results of these tests confirmed the correct functioning of the MDBE system, its compatibility with existing recording equipment, and significant advantages in terms of configuration flexibility and stability of signal path parameters.

Nowadays, all radio astronomy observations at the Quasar VLBI network are performed with the MDBE system. Applying the system in the VLBI mode ensures the successful use of the network's radio telescopes in international observation programs, as well as high-precision geodetic measurements. An example of correlation processing of VLBI observations made with the aid of the MDBE system is given in Figure 4. Observations of source 0059+581 were processed at IAA RAS using a DiFX software correlator [Deller et al., 2007].

Applying the MDBE system to spectral modes makes it possible to effectively perform radio astronomy observations of molecular lines. Figure 5 illustrates

the spectrum of source W3OH obtained with RT-32 in the 1.35 cm range. This example demonstrates the stability of the system and the possibility for obtaining spectra with a high signal-to-noise ratio during digital processing in a wide frequency band. During spectral observations in the 1.35 cm range with RT-32 and the MDBE system (16 MHz bandwidth, 0.488 kHz resolution, 10 min accumulation time), a fluctuation sensitivity of ~ 0.2 K in antenna temperature per spectral channel was achieved. In the radiometer mode in the 3.5 cm range (1024 MHz bandwidth, 1 s time constant), the RMS deviation of output signal does not exceed ~ 0.001 K. These parameters correspond to the best world analogues and confirm the high stability of the MDBE system.

An additional confirmation of the versatility of the system was provided by experimental radar observations of the Moon, performed at the Svetloye Observatory of the Quasar VLBI network [Bondarenko et al., 2024]. During the experiments, spectrograms of echo signals from Archimedes, Tycho, Copernicus craters, the Sea of Clarity, and the landing area of Apollo 15 were obtained. The observations used a 35-meter DSA-3 antenna of the MALARGÜE station (EKA, Argentina) and a 13-meter radio telescope RT-13 of the Quasar VLBI network equipped with the MDBE system. The findings confirmed the possibility of applying the system not only in classical radio astronomy, but also in radar experiments.

CONCLUSION

The transition to digital signal conversion and processing methods is a key direction in the development of state-of-the-art radio astronomy equipment. While at early stages digital methods were only partially used in radio telescopes of the Quasar VLBI network, modern solutions provide fully digital signal processing in a wide frequency band and support for various observation modes.

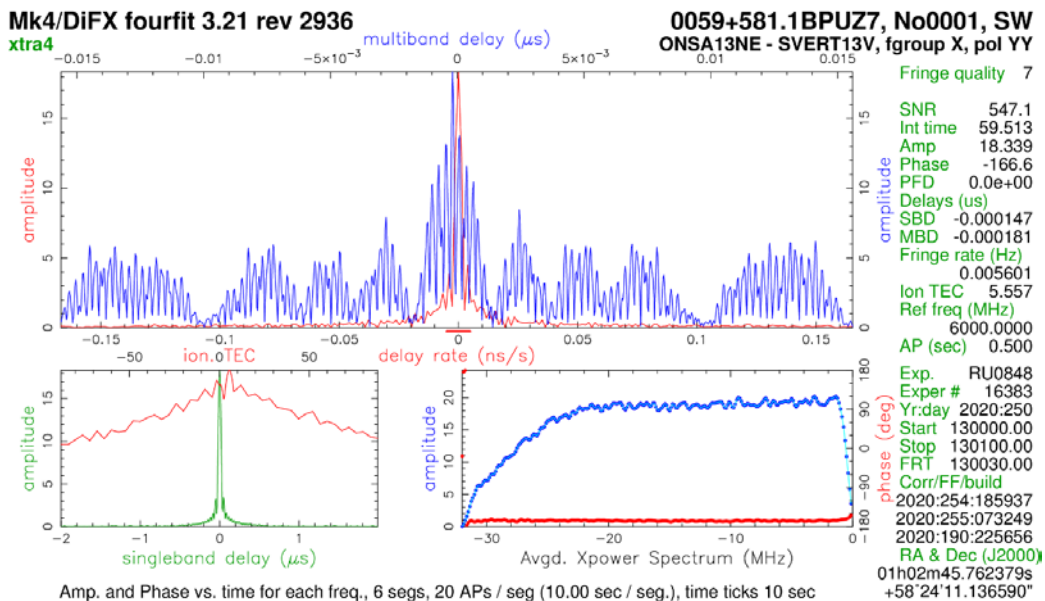

Figure 4. Result of processing of observations of source 0059+581 (RT-13 Svetloye — Onsala, Sweden) with the IAA RAS DiFX correlator, recorded by the MDBE system

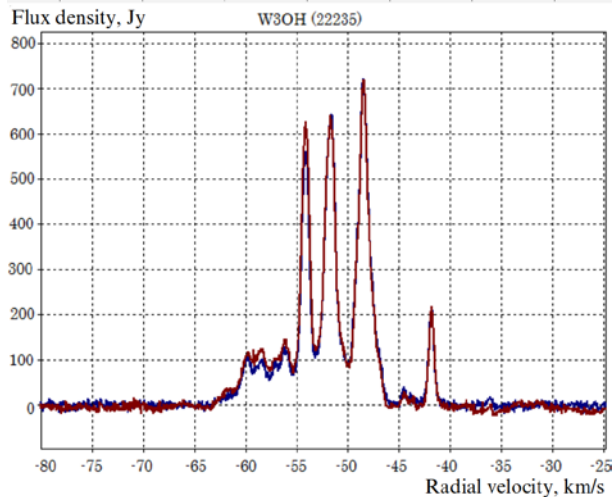

Figure 5. Spectrum of source W3OH obtained by RT-32 (Zelenchukskaya Observatory) in the range of 1.35 cm, using the MDBE system

A multifunctional digital backend (MDBE) system has been developed and implemented at IAA RAS; it is designed for the radio telescopes RT-13 and RT-32 of the Quasar VLBI network. The system provides unification of signal conversion equipment, previously implemented as separate specialized devices, and supports broadband and narrowband VLBI modes, as well as spectral and radiometric observations within a single hardware and software platform.

The operation of the MDBE system under real observation conditions has confirmed the expediency of replacing previously used systems with a single general-purpose system. Adopting the MDBE system has made it possible to increase the stability of signal path parameters, simplify the operation of radio telescopes, and ensure compatibility with domestic and international data recording and transmission standards. At present, all radio astronomy observations at the Quasar VLBI network are carried out using the MDBE system, and since 2023 VLBI sessions on RT-13 have been conducted exclusively with the system.

The prospects for further development of the MDBE system are associated with the expansion of implemented digital processing algorithms, increased resistance to radio frequency interference, development of spectral modes, and research into variable and transient radio sources, as well as integration with virtual observatories (International Virtual Observatory Alliance (IVOA) [<https://www.ivoa.net>]), which will provide access to observational data from the radio telescopes of the Quasar VLBI network through unified international interfaces. This provides the basis for further expansion of scientific and applied problems solved by radio telescopes of the Quasar VLBI network.

REFERENCES

- Bondarenko Yu.S., Marshalov D.A., Zinkovsky B.M., Mikhailov A.G. Radar images of the candidate spacecraft landing sites on the Moon. *Astron. Lett.* 2024, vol. 50, no. 1, pp. 92–97. <https://doi.org/10.1134/S1063773724600127>.
- Deller A.T., Tingay S.J., Bailes M., West C. DiFX: a software correlator for very long baseline interferometry using multiprocessor computing environments. *Publ. Astron. Soc. Pacific.* 2007, vol. 119, iss. 853, pp. 318–336. <https://doi.org/10.1086/513572>.
- Ipatov A.V. A new-generation interferometer for fundamental and applied research. *Physics-Uspexhi.* 2013, vol. 56, no. 7, pp. 729–737. <https://doi.org/10.3367/UFNe.0183.201307i.0769>.
- International Virtual Observatory Alliance.
URL: <https://www.ivoa.net> (accessed December 10, 2025).
- Marshalov D.A., Grenkov S.A., Koltsov N.E., Fedotov L.V. Universal digital signal processing system for radio telescopes. *IAA RAS Transactions* (Proc. Institute of Applied Astronomy RAS). 2024, iss. 71, pp. 9–17. (In Russian). <https://doi.org/10.32876/ApplAstron.71.9-17>.
- Min-Gyu Song, Do-Young Byun, Hyun-Goo Kim, et al. The design of network model for the implementation of e-VLBI. *Publ. Korean Astron. Soc.* 2005, vol. 20, no. 1, pp. 63–71. <https://doi.org/10.5303/PKAS.2005.20.1.063>.
- Nosov E.V. Methods for measuring the signal of the phase calibration of the VLBI radio telescopes. *Radiophysics and Quantum Electronics.* 2019, vol. 62, no. 4, pp. 237–249. <https://doi.org/10.1007/s11141-019-09972-z>.
- Oh S.-J., Roh D.-G., Wajima K., et al. Design and development of a high-speed data-acquisition system for the Korean VLBI Network. *Publ. Astron. Soc. of Japan.* 2011, vol. 63, iss. 6, pp. 1229–1242. <https://doi.org/10.1093/pasj/63.6.1229>.
- Salnikov A.I., Bezrukov I.A., Vasiliev V.V., Vylegzhanin A.V. Experience in the operation of buffering and data transmission systems during 2012–2022. Prospects for development. *IAA RAS Transactions [Proc. Institute of Applied Astronomy RAS]*. 2023, iss. 64, pp. 9–14. (In Russian). <https://doi.org/10.32876/ApplAstron.64.9-14>.
- Sekido M., Takefuji K., Tsutsumi M., Kondo T. Broadband VLBI Data Acquisition System for GALA-V. *IVS NICT TDC News*, 2015, no. 35, pp. 7–11.
URL: https://www2.nict.go.jp/sts/stmg/ivstdc/news_35/tdc_news35.pdf (accessed December 20, 2025).
- Tuccari G., Alef W., Dornbusch S., et al. DBBC3 — the new wide-band backend for VLBI. *Proc. Science (PoS). 14th European VLBI Network Symposium and Users Meeting*. Granada, Spain, 2018, p. 140. <https://doi.org/10.22323/1.344.0140>.
- Vertatschitsch L., Primiani R., Young A., et al. R2DBE: a wide-band digital backend for the Event Horizon Telescope. *Publ. Astron. Soc. Pacific.* 2015, vol. 127, iss. 959, pp. 1226–1239. <https://doi.org/10.1086/684513>.
- Original Russian version: Marshalov D.A., Grenkov S.A., Berdnikov A.S., Fedotov L.V., published in *Solnechno-zemnaya fizika.* 2026, vol. 12, no. 2, pp. 130–136. <https://doi.org/10.12737/szf-121202614>. © 2026 INFRA-M Academic Publishing House (Nauchno-Izdatelskii Tsentr INFRA-M).
- How to cite this article*
Marshalov D.A., Grenkov S.A., Berdnikov A.S., Fedotov L.V. Modern digital backend systems for the radio telescopes of the Quasar VLBI network. *Sol.-Terr. Phys.* 2026, vol. 12, iss. 2, pp. 119–124. <https://doi.org/10.12737/stp-121202614>.